

# EMPOWERING CONCEPTUAL DESIGN VIA THE SINGLE MODELING ENVIRONMENT

White Paper

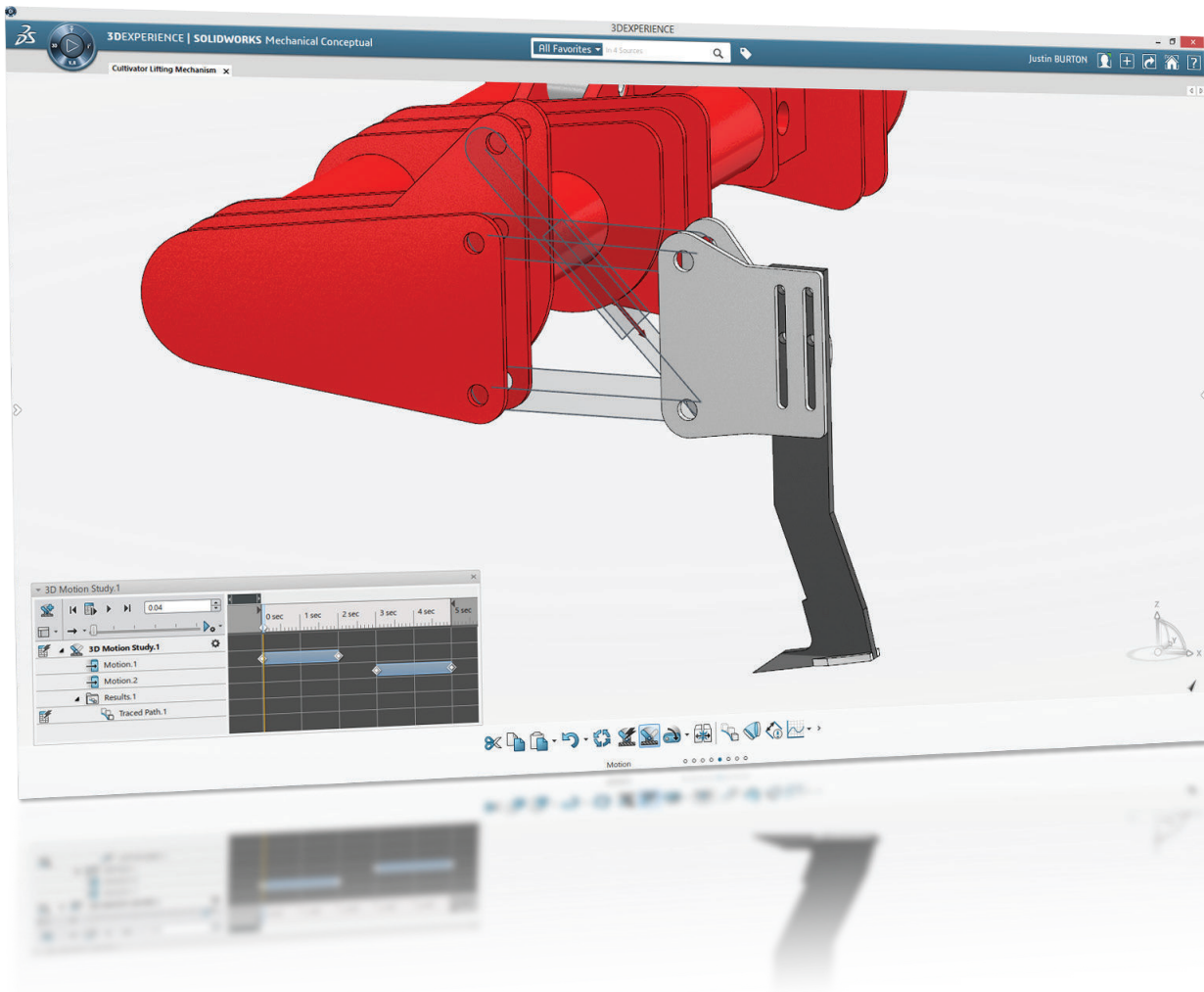

Developing innovative design concepts is critically important to the success of product development organizations, large and small, because these ideas lay the foundation for future business success. Using conventional CAD software for conceptual design presents challenges because traditional modeling tools—developed to finalize designs and support manufacturing/assembly—constrain the freedom, flexibility, and creativity that drive effective conceptual design. With the SOLIDWORKS® Conceptual Designer single modeling environment, design engineers have a dedicated platform that is completely focused on quickly capturing, developing, and communicating design ideas and concepts.

## THE CONCEPTUAL DESIGN ENVIRONMENT: WHERE THE MAGIC HAPPENS!

Innovation dominates the future of virtually all manufacturing companies. Manufacturers that can stimulate innovation in product development—improving upon existing products while simultaneously pursuing new product ideas—will likely succeed, while those that are content with maintaining the status quo will probably go the way of the dinosaurs. There’s no room for complacency in a global economy where strong competitors and market-disrupting products can rapidly emerge from virtually any part of the world.

Facilitating innovation in product development requires a focus and commitment on conceptual design because that’s where innovation begins. Those magical “eureka” moments—when inspiration and creativity result in innovation—generally don’t occur when an engineer is adding detail features to a model, outputting drawings, or releasing designs to manufacturing. The same focus on modeling, evaluating, and outputting manufacturable designs from a practical production standpoint—which makes traditional CAD tools so useful for efficiently developing and making products—also limits their utility for conceptual design, which is where the innovation magic typically happens.

Manufacturers who understand the importance of innovation view conceptual design as the engine of growth and rely on their design engineers to keep the conceptual design pipeline full. However, design engineers who are tasked with transforming innovative ideas into potential product concepts have a different frame of reference than production-focused design engineers and require a more dedicated conceptual design approach. While traditional CAD tools satisfy most product development requirements, they do not sufficiently address the needs of conceptual designers.

Because inspiration comes from many places, conceptual designers need a means for gathering information from numerous sources, for collaborating with key stakeholders with varying points of view, and for establishing overall design requirements. They need to be able to quickly capture innovative concept ideas, explore a range of “what if” scenarios, and evaluate multiple design concepts. In short, conceptual designers need an instinctive single modeling environment.



---

Successful new product innovation begins with conceptual design to quickly capture ideas and explore concepts in an instinctive, collaborative single modeling environment.

## EXISTING CHALLENGES TO EFFECTIVE CONCEPTUAL DESIGN

The greatest impediment to effective conceptual design is that it doesn't get the attention and resources required to separate it from everyday product development processes. 3D CAD, simulation, and product data management solutions certainly pay dividends in terms of generating productivity gains in developing, optimizing, and manufacturing products. However, because these tools were designed to "develop" rather than "conceptualize", they require production-related steps that are completely unrelated to what conceptual designers are ultimately trying to achieve, which is to create, communicate, and capture innovative concepts. This focus on production makes the use of traditional CAD tools for conceptual design both time-consuming and cumbersome, leading to a lack of time for and concentration on the development of innovative concepts.

For example, how can a design engineer gather information, communicate with all stakeholders (including some that don't utilize CAD tools), and then quickly incorporate stakeholder input into a single modeling environment that doesn't carry the data overhead associated with creating parts and assemblies for production? How does the conceptual designer instinctively leverage his or her creativity and inventiveness when the traditional CAD data structure—with numerous links and references between parts, drawings, and assemblies—continually gets in the way? How do conceptual designers maintain their creative flow when they repeatedly must attend to tasks that are unrelated to concept development?

What conceptual designers desperately need is a "white board for the mind", a platform where they can quickly model, share, test, modify, document, and save design concepts in an instinctive, intuitive way that's removed from traditional CAD modeling approaches and unassociated with the downstream CAD concerns that are inherent to production-centric development. They require a single, unfettered modeling environment that is solely designed to focus their complete attention and creative talent on concept development, without the potential distractions and additional tasks involved with product development. This single modeling environment forms the basis of SOLIDWORKS Conceptual Designer.

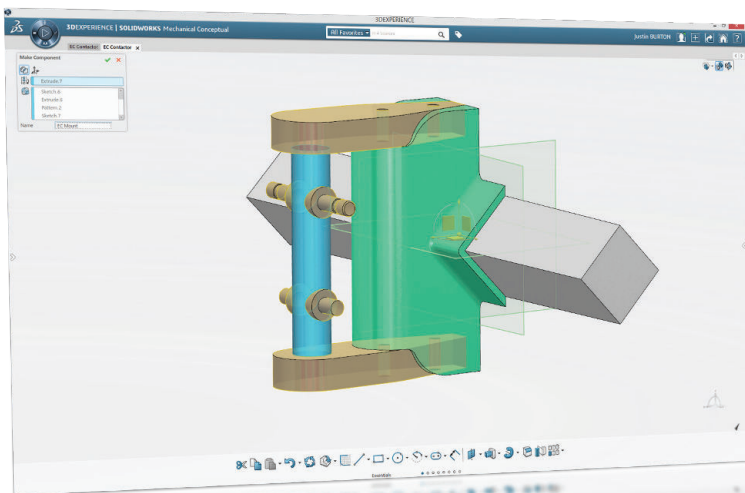

## THE SINGLE MODELING ENVIRONMENT—A NEW PARADIGM FOR CONCEPTUAL DESIGN

The single modeling environment for conceptual design establishes a new, instinctive paradigm for how design engineers create new mechanical design concepts and work with conceptual geometries. By stripping out all unrelated tasks and distractions, streamlining user interaction with conceptual ideas and models, and integrating communication and collaboration capabilities, the single modeling environment makes conceptual design more efficient, instinctive, focused, and productive.

### Increased Efficiencies

Conceptual design becomes more efficient with the single modeling environment because engineers can create, capture, and communicate design concepts in real time. The single modeling environment is designed to develop design concepts in a more natural way. Thus, every task, tool, and capability contributes to advancing concept development in a flexible, unconstrained manner. This approach enables design engineers to efficiently identify innovative ideas for further development while weeding out untenable concepts, maximizing constructive work while eliminating wasted time. By making conceptual design more efficient, manufacturers can stimulate innovation without taking away from everyday product development resources.

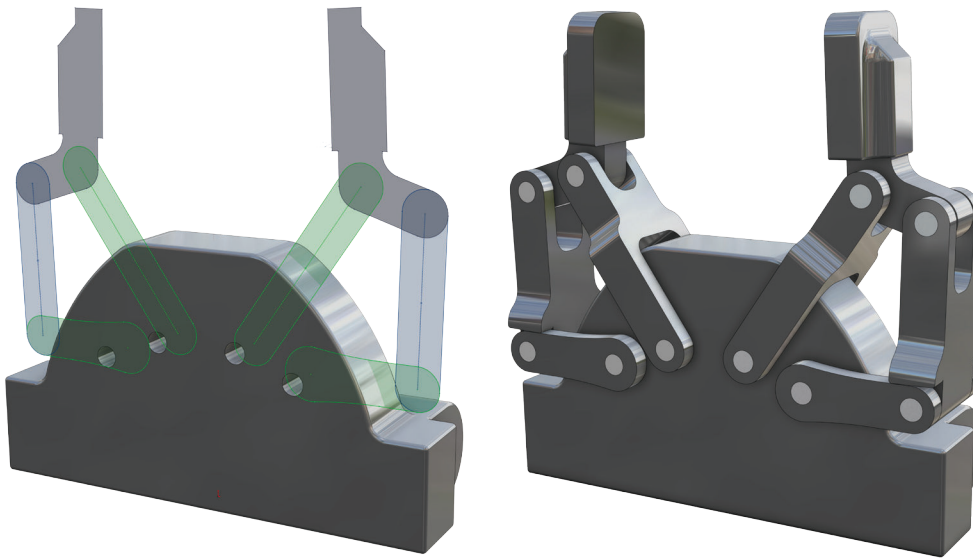

### Greater Freedom

The single modeling environment liberates design engineers from the distractions, constraints, and decision-making of traditional CAD tools. It allows conceptual designers to ignore product assembly structures, which gives them the freedom to innovate new concepts in an unconstrained design environment. Designers don't have to worry about the myriad requirements for creating, manufacturing, or documenting parts, drawings, and assemblies. Because the single modeling environment gives design engineers a dedicated, instinctive, and liberated design space for modeling, sharing, testing, modifying, documenting, and saving new concepts, it stimulates their creativity to generate the innovative ideas that fuel future manufacturing success.

## Improved Focus

Focus is the undisputed foundation of conceptual design. Without an intense focus on the problem or need, the spontaneity and inspiration that drive innovative solutions cannot take shape, and promising ideas cannot emerge, build, and coalesce into successful products. The single modeling environment facilitates and targets your organization's conceptual design focus with laser-like precision. With the design freedom afforded by the single modeling environment, design engineers are free to design and innovate without having to make any of the premature decisions that are usually foisted upon them by traditional CAD data structures. In other words, freedom and focus combine to produce innovation because designers can think about the design, not the design tool.

## Save and Maintain Innovative Ideas

Of course, a key requirement of the single modeling environment is the ability to save, extract, and leverage the results of all of this freewheeling conceptual design activity. While maintaining data related to promising product concepts is quite obviously a necessity, it's also important to capture ideas that don't work out—not only to prevent future conceptual designers from going down the same blind alleys, but also to document information and findings that may influence the development of other concepts or uses. For example, although a design concept may not fit an immediate need or particular situation, it may have other potential applications. Capturing conceptual design creativity and innovation—including both the successes and failures—is an important aspect of the single modeling environment. With it, designers can grow capture, and maintain design intelligence within their companies.

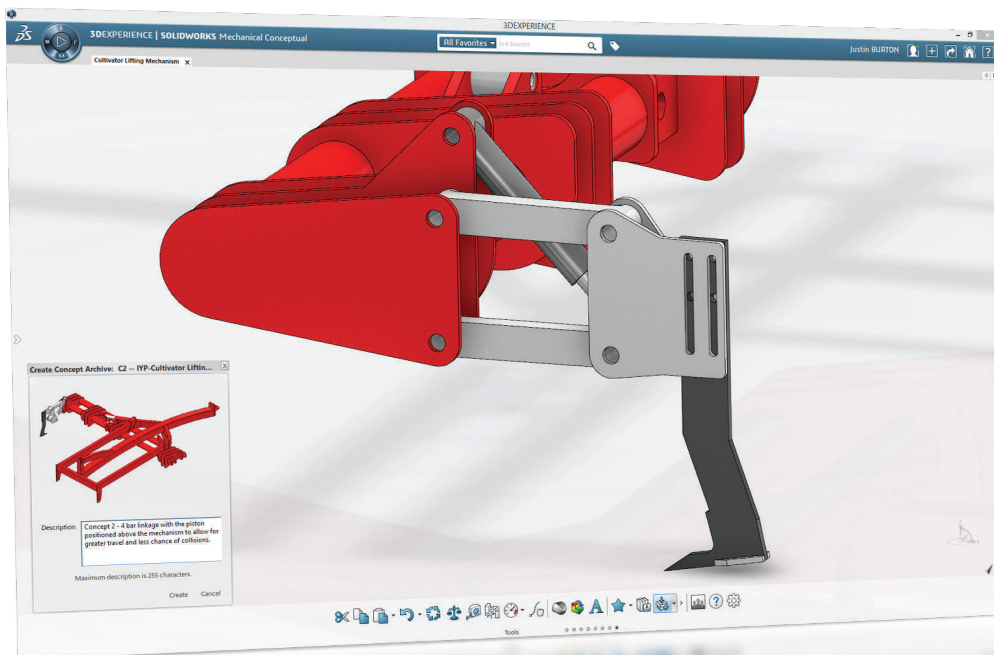

## **SOLIDWORKS CONCEPTUAL DESIGNER—INNOVATIVE SINGLE MODELING ENVIRONMENT FOR CONCEPTUAL DESIGN**

With the release of SOLIDWORKS Conceptual Designer, Dassault Systèmes has introduced the first, true single modeling environment for conceptual design. Unlike any other design software—in terms of architecture, appearance, and functionality—SOLIDWORKS Conceptual Designer brings the **3DEXPERIENCE**® to conceptual designers, providing important utility and performance advantages that improve the conceptual design process and result in greater innovation and efficiency. The solution allows conceptual designers to perform all functions—such as sketching ideas, creating geometry, defining design requirements, communicating with stakeholders, reviewing concepts, modifying models, borrowing from other designs, or simulating performance—all from within a single, flexible cloud-based conceptualization application. Having everything in one place simplifies use of the tool, which aids conceptual design.

### **Faster Conceptual Design**

SOLIDWORKS Conceptual Designer makes conceptual design more efficient because of the fluid, living nature of its cloud-based, thick-client architecture. While the application is initially accessed from and all data is saved to the cloud, robust functionality is maintained locally with only intermittent contact with the cloud server. This enables designers to conceptualize, communicate, and collaborate anywhere that they have web access. Design engineers don't have to waste time working across different applications or modules, or making decisions based on traditional CAD or production-related constraints. There's no need to import or export data, leave the environment to search for parts or existing designs, or worry about how part and assembly data will reference each other. With SOLIDWORKS Conceptual Designer, design engineers can effortlessly perform and coordinate every step associated with conceptual design directly from within the software's single modeling environment.

### **Better Communication**

Communicating with key stakeholders is easier and more effective with SOLIDWORKS Conceptual Designer, regardless of whether stakeholders have or use CAD tools. This is an important capability because it empowers conceptual designers to communicate with all stakeholders in the most convenient, efficient, and effective ways. For example, with CAD tools, designers would generally have to prepare a presentation, schedule meetings, and project their CAD screen to communicate with management, marketing, financial, partner, and customer stakeholders. SOLIDWORKS Conceptual Designer establishes a social media-like network comprising all key players, which supports fluid, dynamic communication to and from computers, tablets, and smartphones. There is no CAD requirement, and stakeholders can use any of the standard web browsers (i.e., Chrome™, Firefox®, and Internet Explorer®) and their preferred devices to participate in the conceptual design conversation.

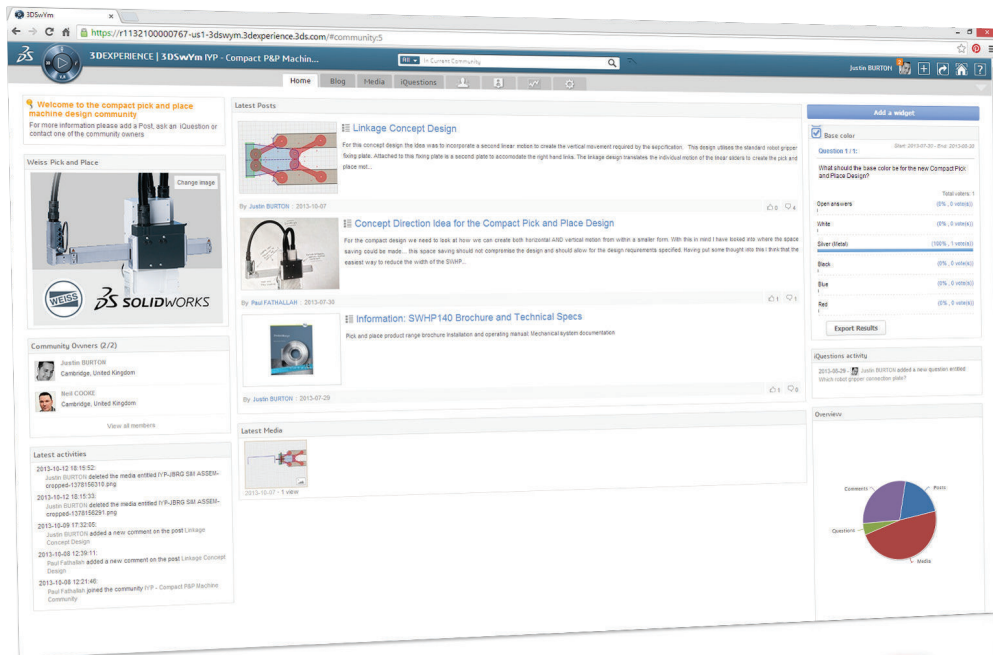

## Incorporating Inputs in Real Time

SOLIDWORKS Conceptual Designer allows designers to modify new mechanical concepts to incorporate input and feedback in real time without ever leaving the single modeling environment. There's no need to go away from the design concept to attend meetings or solicit input and feedback. Everyone who can contribute to concept development can review new ideas inside a standard browser and offer insights directly to conceptual designers using SOLIDWORKS Conceptual Designer. This critical social networking information is communicated from within the same cloud-accessed application that designers use to create, model, and evaluate innovative concepts. It's as simple as modifying a concept as soon as a legitimate suggestion or comment is received.

## Enjoy Greater Flexibility

Increased flexibility is the hallmark of SOLIDWORKS Conceptual Designer, allowing designers to create concepts in 3D in an easier, more free-flowing, and instinctive manner. The software's design tree enables designers to use sketches, primitives, features, bodies, components, or any combination of these—in 2D or 3D—with all tools, commands, and functionality available from a single, intuitive workspace. Starting design concepts with 2D sketches or primitives gives designers an easy path to quickly generate 3D components. The solution's greater flexibility is especially evident in its Direct Editing capabilities, which let designers turn off parametric relationships and free their ability to manipulate geometry. Additional intelligent component tools allow designers to carry assembly motion behavior information from a component in one concept to the same component used in another concept.

## Spark Creativity and Innovation

With SOLIDWORKS Conceptual Designer, designers can focus their attention on concepts instead of the design environment, leading to higher levels of creativity and innovation. Greater speed and fewer design constraints empower designers to imagine, explore, and evaluate more design options in less time, resulting in higher levels of innovation, while capturing all conceptual design activity for future use. Although not all design concepts may be ready for immediate development, the SOLIDWORKS Conceptual Designer single modeling environment provides a platform for stimulating new, more creative approaches to product design that can lead to sustained innovation as part of ongoing product development.

## Capturing and Retaining Conceptual Design Activity

What happens to all of the ideas that a designer explores but may not utilize in a particular design? SOLIDWORKS Conceptual Designer transparent data management capabilities facilitate the capture, retention, and management of all conceptual design activity. All concept ideas are valuable. While some ideas may never pan out, others may pay huge dividends in the development of future or different products. With SOLIDWORKS Conceptual Designer, all design activity is maintained in a tagged concept archive that designers can access tomorrow, next week, or even years from now. With SOLIDWORKS Conceptual Designer, ideas are not lost, but saved for future use.

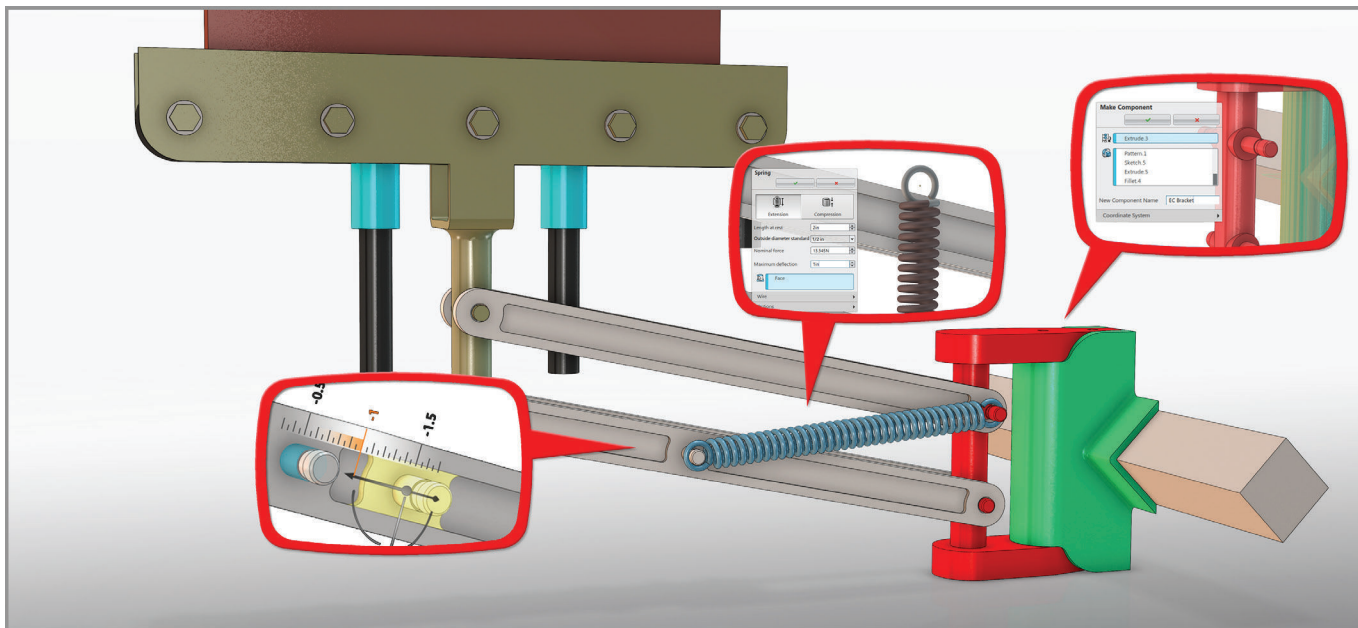



## SOLIDWORKS CONCEPTUAL DESIGNER SINGLE MODELING ENVIRONMENT DRIVES INNOVATION IN CONCEPTUAL DESIGN

Innovation in design solutions mirrors innovation in product development. The design engineer's toolset has dramatically evolved over the past few decades—from manual drafting to computer-aided design techniques and from 2D CAD tools to 3D parametric systems. SOLIDWORKS Conceptual Designer represents the next evolutionary advance in conceptual design.

By providing a single modeling environment that is entirely focused on the needs of conceptual designers, SOLIDWORKS Conceptual Designer helps manufacturers emphasize, facilitate, and stimulate innovation. The solution brings the power of the **3DEXPERIENCE**® to the beginning of the product development process, establishing a nuanced, dedicated platform that can elevate conceptual design from a function that enterprises want to improve to a dynamic force for future growth. When conceptual designers can more easily and quickly model, share, test, modify, document, and save new design ideas and concepts, they can more successfully complete the groundwork that leads to the development of the innovative products that drive future manufacturing success.

To learn more about how the flexible, powerful SOLIDWORKS Conceptual Designer single modeling environment can improve your conceptual design process, visit [www.SOLIDWORKS.com](http://www.SOLIDWORKS.com) or call 1 800 693 9000 or 1 781 810 5011.

---

### Our 3DEXPERIENCE platform powers our brand applications, serving 12 industries, and provides a rich portfolio of industry solution experiences.

Dassault Systèmes, the 3DEXPERIENCE® Company, provides business and people with virtual universes to imagine sustainable innovations. Its world-leading solutions transform the way products are designed, produced, and supported. Dassault Systèmes' collaborative solutions foster social innovation, expanding possibilities for the virtual world to improve the real world. The group brings value to over 170,000 customers of all sizes in all industries in more than 140 countries. For more information, visit [www.3ds.com](http://www.3ds.com).



**3DEXPERIENCE**